

REV.	DESCRIPTION	DATE
A	INITIAL RELEASE	10/4/2025
B	CHANGE FROM 0.065" TO 0.083" THICKNESS TUBING AND ADD COPE	10/20/2025
C	COPE UPDATES	10/29/2025

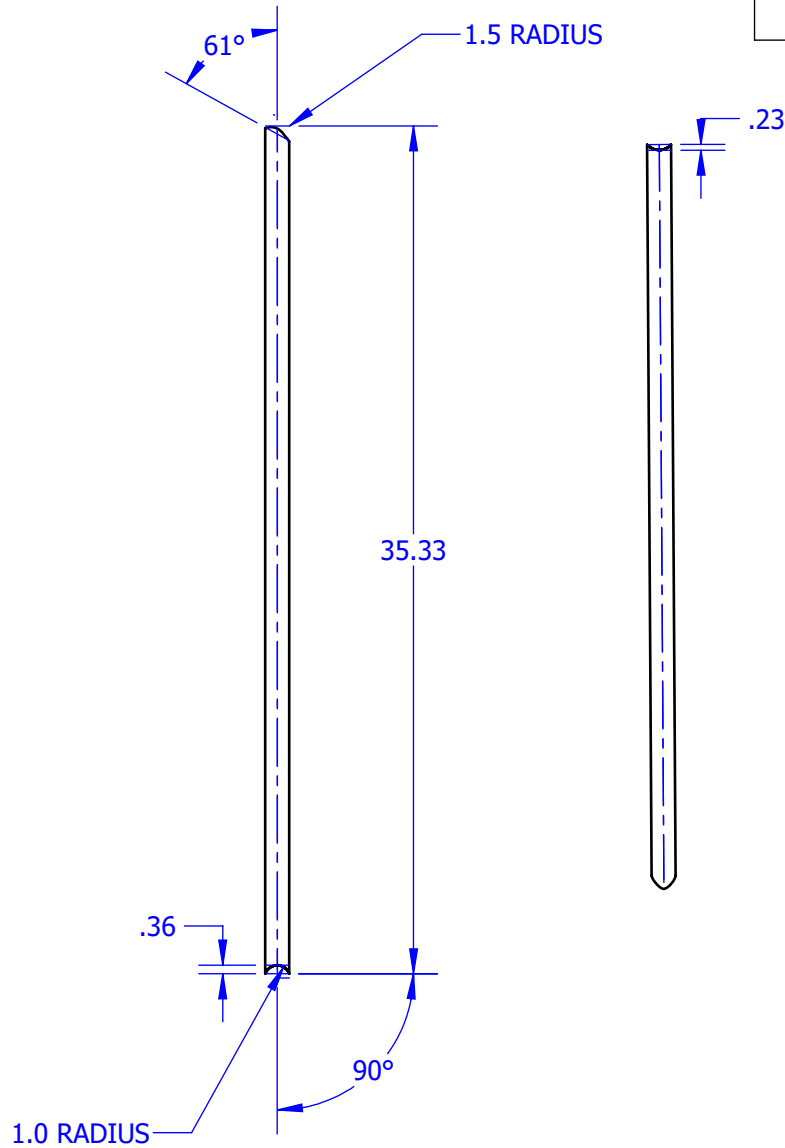

SPONSOR PROJECT TEAM NUMBER	MCEN 3025 TEAM ROCKET	dc DESIGN CENTER COLORADO <small>DESIGN • BUILD • FLY</small>	
TOLERANCES UNLESS NOTED:	X.X ± X.XX ±0.010 X.XXX ±0.005	FILE NAME BOTTOM_BEAM-4.0	APPROVAL
UNITS: INCHES	X.X° ±0.5°	MFD BY	
DRAWN BY JA	DRAWN DATE 10/20/25	DESCRIPTION BOTTOM BEAM	
MATERIAL PLAIN CARBON STEEL	STOCK SIZE 1" OD X 0.083" WALL TUBE	PN	REV C
PROPRIETARY AND CONFIDENTIAL			SHEET 1 of 1
THE INFORMATION CONTAINED IN THIS DRAWING IS THE SOLE PROPERTY OF THE DESIGN CENTER. ANY REPRODUCTION IN PART OR AS A WHOLE WITHOUT WRITTEN PERMISSION IS PROHIBITED.			